

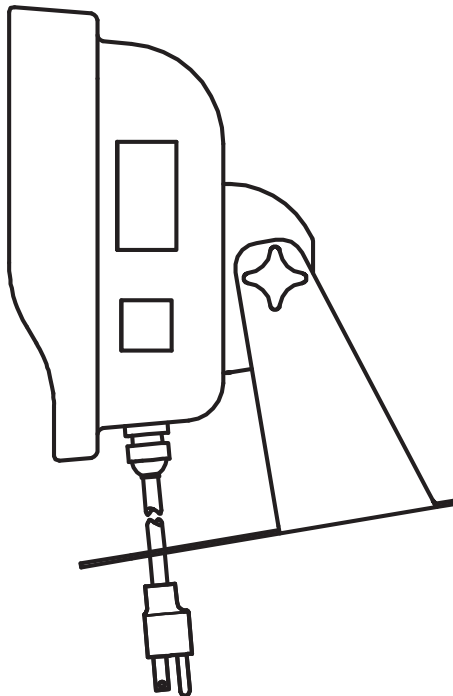

LEGAL FOR TRADE 212G WEIGHT INDICATOR

212G

- 0.8" LCD Display
- 1x AC Power Cable
- 5x Gland Conn.
- Legal for Trade Ind.

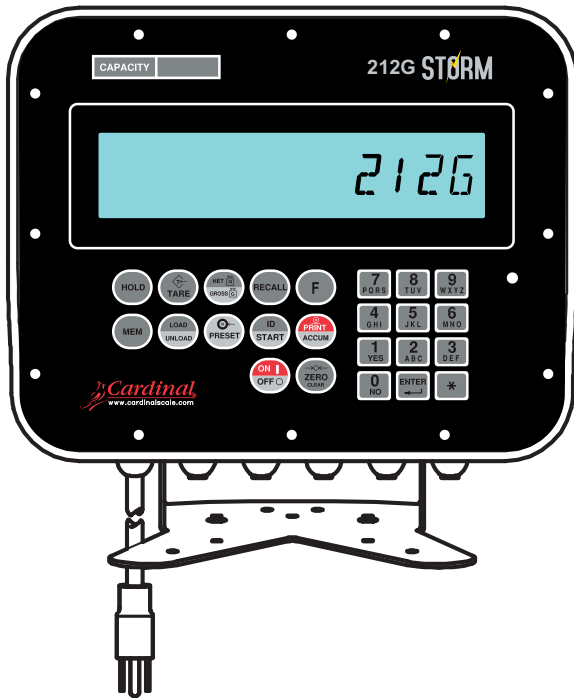

212GX

- 2" LCD Display
- 1x AC Power Cable
- 5x Gland Conn.
- Legal for Trade Ind.

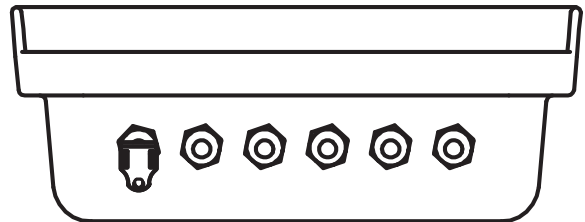

Option 4 - Mounting

212DESKMOUNT

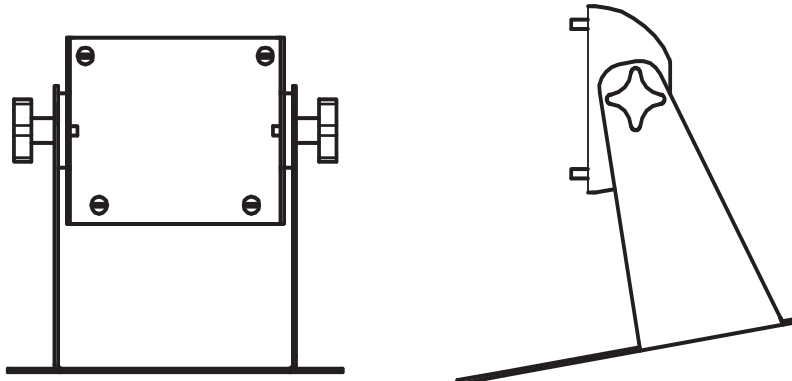

(a)

212VMOUNT

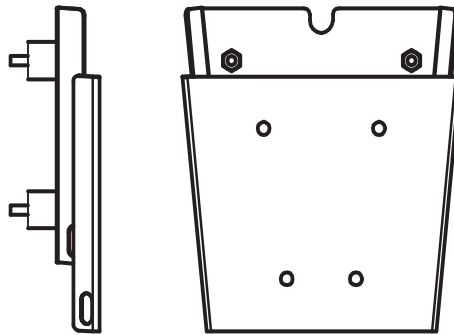

(b)

AGVBRCKT

(extra)

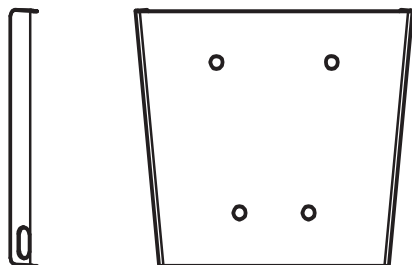

(c)

Cardinal Scale reserves the right to improve, enhance or modify features and specifications without prior notice. All registered trademarks are the property of their respective owners.

 **Cardinal**[®]
Cardinal Scale Manufacturing Co.
203 E. Daugherty, Webb City, MO 64870 USA
Ph: 417-673-4631 or 800-441-4237 • Fax: 417-673-5001
www.CardinalScale.com

SOLD BY: