

THESE TWO NUMBERS INDICATE WHAT THE SCALE CAPACITY IS IN TONS

THESE THREE NUMBERS INDICATE THE SCALE MODEL

SELECT ONE VERSION OF THIS LSC MODEL

1217
 2535
 3052

THESE TWO NUMBERS INDICATE THE APPROXIMATE SCALE LENGTH

XXXX-LSC-1D

THIS LETTER SPECIFIES EITHER A SINGLE OR DUAL LATCH (EITHER S OR D)

THIS NUMBER INDICATES WHICH OPTION TO USE FOR GATE SWING (1,2,3,OR 4)

- SINGLE LATCH: XXXX-LSC-1S
- DUAL LATCH: XXXX-LSC-1D

OPTION 1

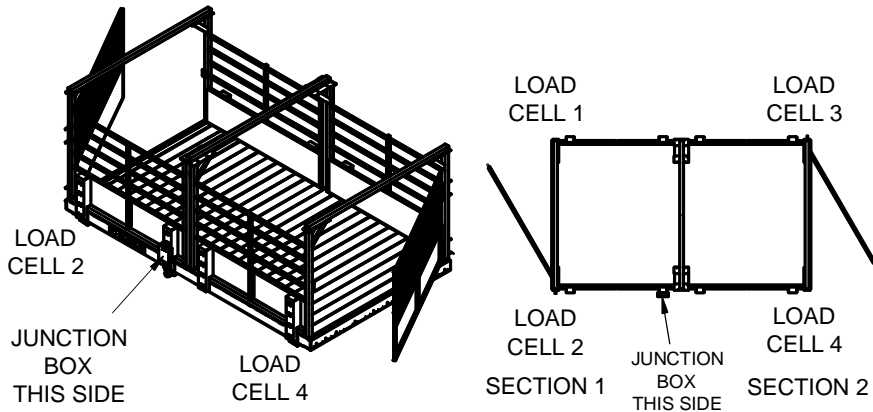

- SINGLE LATCH: XXXX-LSC-2S
- DUAL LATCH: XXXX-LSC-2D

OPTION 2

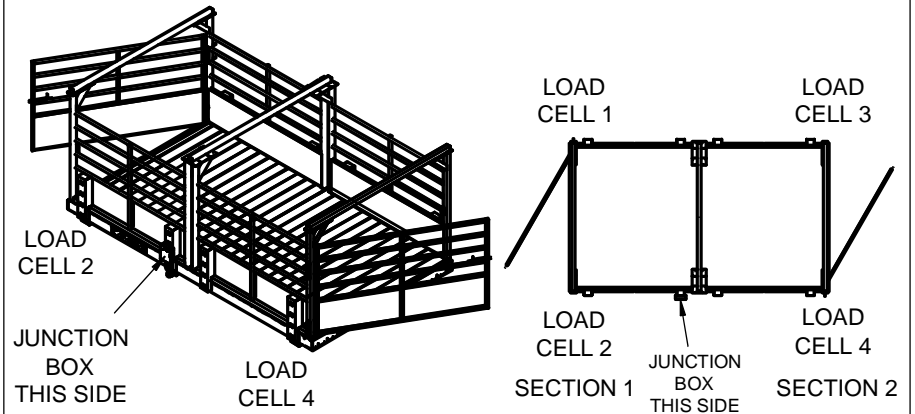

- SINGLE LATCH: XXXX-LSC-3S
- DUAL LATCH: XXXX-LSC-3D

OPTION 3

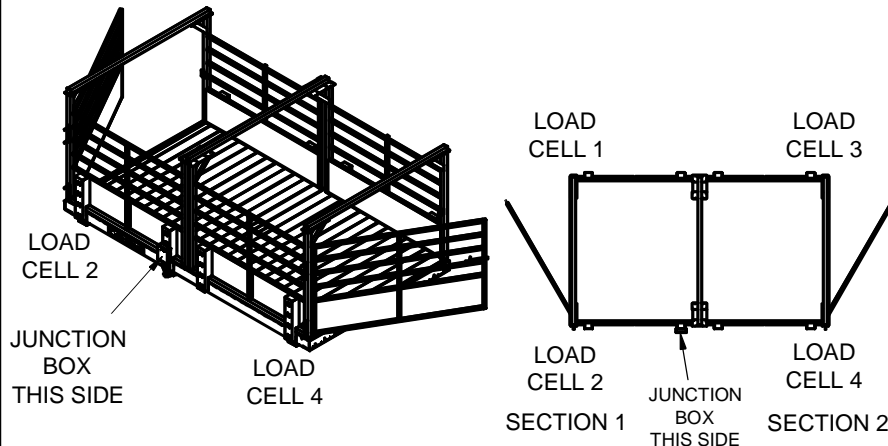

- SINGLE LATCH: XXXX-LSC-4S
- DUAL LATCH: XXXX-LSC-4D

OPTION 4

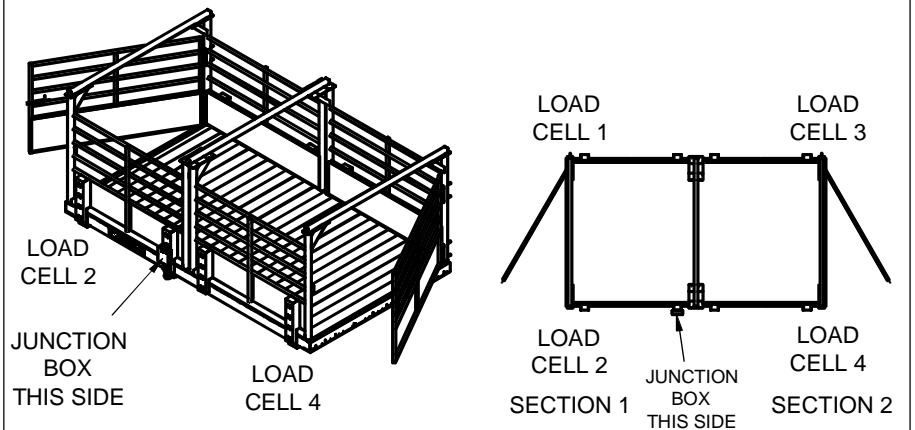

CARDINAL SCALE MFG. CO. REQUIRES THIS FORM TO BE FILLED OUT AND RETURNED PRIOR TO SCHEDULING OR BUILDING.

COMPANY NAME: _____	CUSTOMER SIGNATURE: _____	COMPANY P.O. NUMBER: _____	CARDINAL S.O. NUMBER: _____
			DATE: _____