

SMART CELL[®]

DIGITAL LOAD CELLS

SCBD S E R I E S

COMPONENTS + SPECIFICATIONS GUIDE

Cardinal Scale's SCDC series load cells and electronics provide everything you need for a vehicle scale, minus the weighbridge.



	MODEL #	DESCRIPTION
	SCBD75	34,000 kg / 75,000 lb capacity digital double-ended shear beam load cell
	SCBD100	45,000 kg / 100,000 lb capacity digital double-ended shear beam load cell
	6010-00001	50 mm / 2 inch diameter, grade 1000 hardened ball bearing, 52100 chrome
	0330-0048-08	Load cell bearing cup receiver
	0331-0107-0A	axis [®] load cell stand weldment for SCBD
	0330-0050-08	Lower receiver bearing cup
	0330-0125-18	Load cell end pivot plate (two required per SCBD load cell)
	0330-0065-08	15 ft / 4.5 m long load cell interconnect cable
	0330-0066-08	27 ft / 8.2 m long load cell interconnect cable
	0330-0443-08	37 ft / 11.2 m long load cell interconnect cable
	0330-0067-08	Load cell end terminator
	6610-1308	Screw terminal connector homerun cable
	6610-1307	Solder terminal connector homerun cable
	225D	225 Navigator weight indicator with digital load cell connectivity
	225-DLC	Digital load cell option card for 225 indicator (included in 225D)
	825D	825 Spectrum weight indicator with digital load cell connectivity
	825-DLC	Digital load cell option card for 825 indicator (included in 225D)



SMARTCELL[®]
DIGITAL LOAD CELLS

SCBD
SERIES

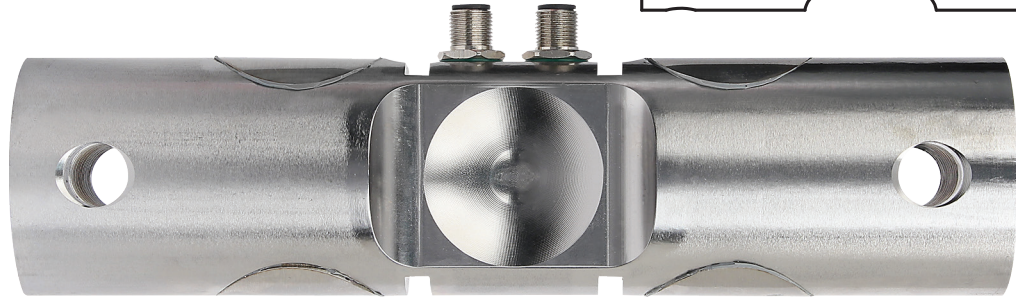
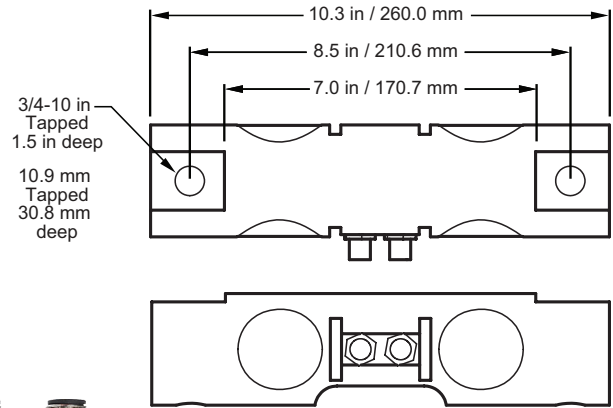

SPECIFICATIONS

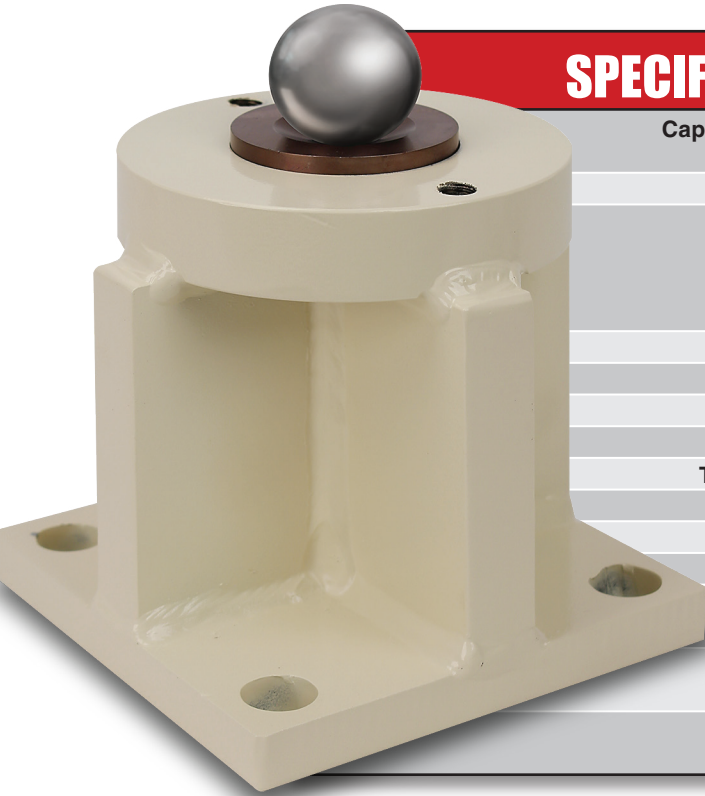

Capacity	SCBD-75K	22,700 kg / 50,000 lb
	SCBD-100K	45,000 kg / 100,000 lb
Cell Type	Digital double-ended shear beam	
Potting	Completely encapsulated and filled with a potting compound to fill all internal voids and prevent any potential for moisture entering the load cell and causing premature failure	
Rated Output	Cardinal digital output	
Protection Class	IP69K rated	
Connectors	5-Pin, M12 Male, A-Coding	
Safe Load	150% rated capacity	
Temperature Range	-10°C to 40°C (14°F to 104°F)	
NTEP Certification	16-088A1	
OIML Certification	R60/2000-GB1-17.17	
Country of Origin	USA	
Accuracy Class	IIIL	
Construction	Stainless steel	
Includes	iSite remote diagnostic monitoring software with e-mail and text alerts	
Mounting	Mounts into Cardinal axis [®] brand ball receiver cup load cell stand	

Cardinal Scale reserves the right to improve, enhance, or modify features and specifications without prior notice.

SOLD BY:

Cardinal[®]
Cardinal Scale Manufacturing Co.
203 E. Daugerty, Webb City, MO 64870 USA
Ph: 417-673-4631 or 800-441-4237 • Fax: 417-673-2153
www.CardinalScale.com

Mobile: m.cardinalscales.com