

# SP-LM Series

## Single Point, Stainless Steel Heavy Capacity Load Cells



### SPECIFICATIONS

<b>Overload</b>	Safe: 150% Ultimate: 300%
<b>Output mV/V</b>	2 ± 10%
<b>Resistance</b>	Input: 369 - 408 ohms Output: 350 ± 5 ohms
<b>Zero Balance</b>	± 1% of rated output
<b>Excitation / AC-DC</b>	15 VDC maximum
<b>Non-linearity</b>	± 0.03% of rated output
<b>Hysteresis</b>	± 0.03% of rated output
<b>Non-repeatability</b>	± 0.02% of rated output
<b>Creep</b>	± 0.03% of load in 20 min.
<b>Deflection</b>	.012-inch to .020-inch
<b>Insulation Resistance</b>	5,000 megohms
<b>Protection Class</b>	IP-65
<b>Accuracy Class</b>	C3
<b>Temperature Range</b>	Compensated: 14°F to 104°F Operating: -20°F to +200°F
<b>Temperature Effect</b>	Rated Output: ± 0.0008%/ F of load Zero Balance: ± 0.0015%/ F of rated output

- **200 lb to 1,000 lb capacities**
- **Highly resistant to eccentric loads**
- **Stainless steel construction for the ultimate durability**
- **Direct mounting to weighing platform**
- **7-ft/2.1-m integral shielded cable**
- **VCAP certified**

Cardinal Scale's SP-LM series single point load cells are manufactured for heavier capacity weighing. These cells are fabricated from stainless steel and are available in capacities from 200 lb to 1,000 lb.

The unique design of Cardinal's single point load cells offers cost-saving advantages for many weighing applications. The load cell can be mounted directly to the weighing platform, thereby eliminating flexures, pivots, bearings and mechanical levers. All load cells feature threaded mounting holes, proprietary sealant, and a 7-ft / 2.1-m integral multiconductor cable secured by a strain relief seal.

LOAD CELLS

SP-LM

# Single Point SP-LM Series

## Heavier-Capacity, Stainless Steel Load Cells

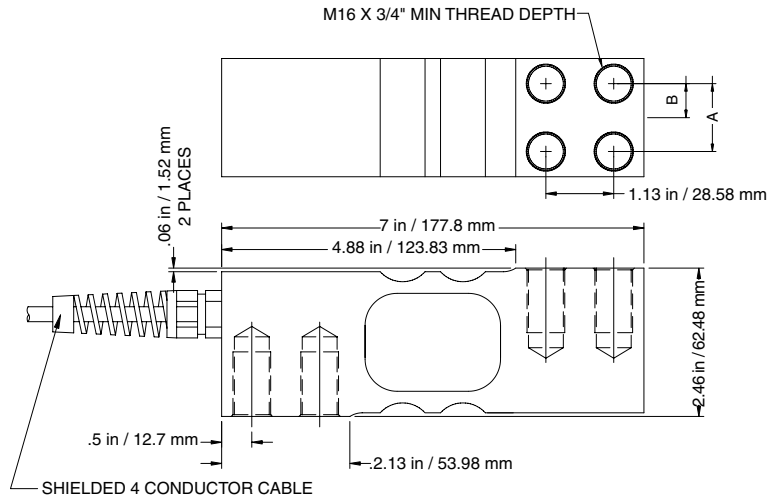
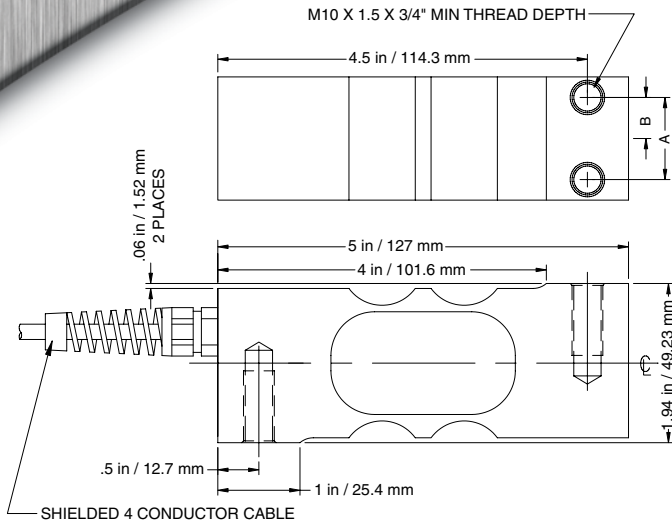

MODEL	CAPACITY	"A"	"B"
SP-200LM	200 lb / 90 kg	1 in / 25.4 mm	0.5 in / 12.7 mm

MODEL	CAPACITY	"A"	"B"
SP-500LM	500 lb / 225 kg	1.125 in / 28.6 mm	0.562 in / 14.3 mm
SP-1000LM	1,000 lb / 455 kg	1.125 in / 28.6 mm	0.562 in / 14.3 mm

### ELECTRICAL INFORMATION

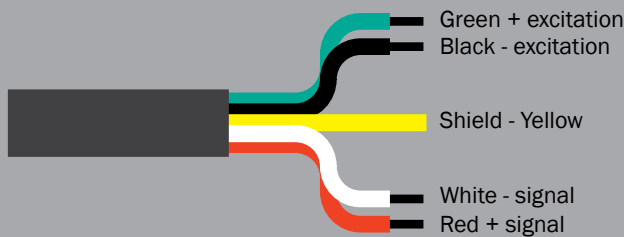

### State-of-the-Art Load Cell Manufacturing Facility ISO 9001 Quality Environment



### VCAP CERTIFIED

Cardinal Scale has been formally audited and found to be fully compliant with the Verified Conformity Assessment Program (VCAP) administered by the National Type Evaluation Program (NTEP) of the National Conference on Weights and Measures (NCWM).

Cardinal Scale reserves the right to improve, enhance or modify features and specifications without prior notice. All registered trademarks are the property of their respective owners.

**Cardinal**  
Cardinal Scale Manufacturing Co.  
203 E. Daugerty, Webb City, MO 64870 USA  
Ph: 417-673-4631 or 800-441-4237 • Fax: 417-673-5001  
[www.CardinalScale.com](http://www.CardinalScale.com)

**SOLD BY:**

