

SnapStream Options Guide

Wireless Scale Systems



SNAP-4

- 1 small junction-box style enclosure
- Up to 4 load cells input
- Radio antenna & cable for wireless output

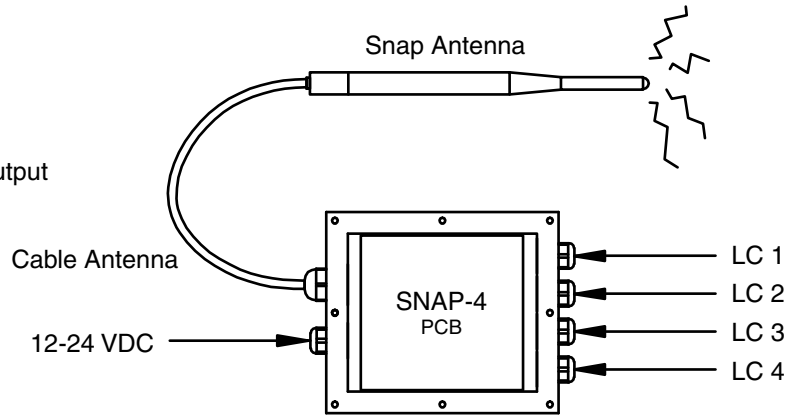

SNAP-8

- 1 "Snap Scalebox 2"
- Up to 8 load cells input
- 1 "Snap RF-Box"
- SNAP-COM & radio antenna for wireless output
- Power supply panel for 120VAC to DC converter
- Optional to install panel in scalebox enclosure
- 12-24VDC + RS232 communications cable between 2 boxes

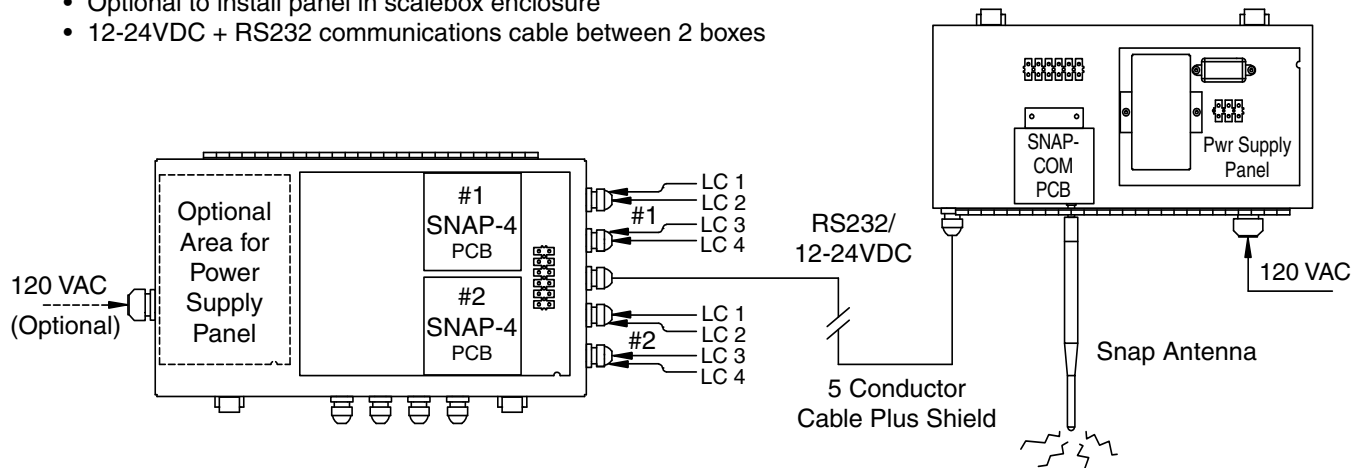

SNAP-12

- 1 “Snap Scalebox 3”
- Up to 12 load cells input
- 1 “Snap RF-box”
- SNAP-COM & radio antenna for wireless output
- Power supply panel for 120VAC to DC converter
- Optional to install panel in scalebox enclosure
- 12-24VDC + RS232 communications cable between 2 boxes

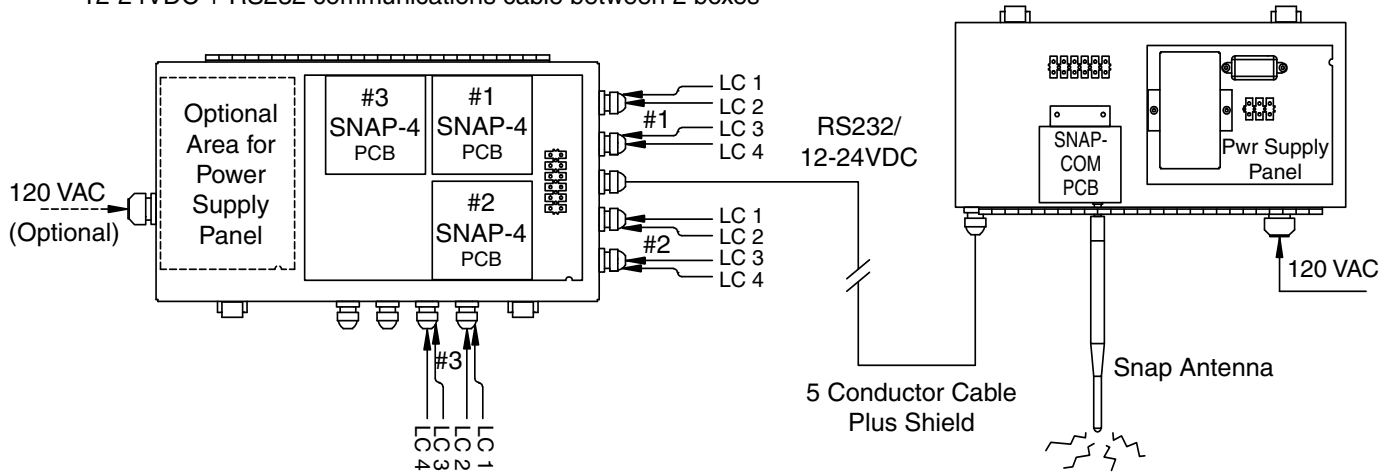

SNAP-16

- 2 “Snap Scalebox 2”
- Up to 16 load cells input
- 1 “Snap RF-box”
- SNAP-COM & radio antenna for wireless output
- Power supply panel for 120VAC to DC converter
- Optional to install panel in scalebox enclosure
- 12-24VDC + RS232 communications cable between 2 boxes

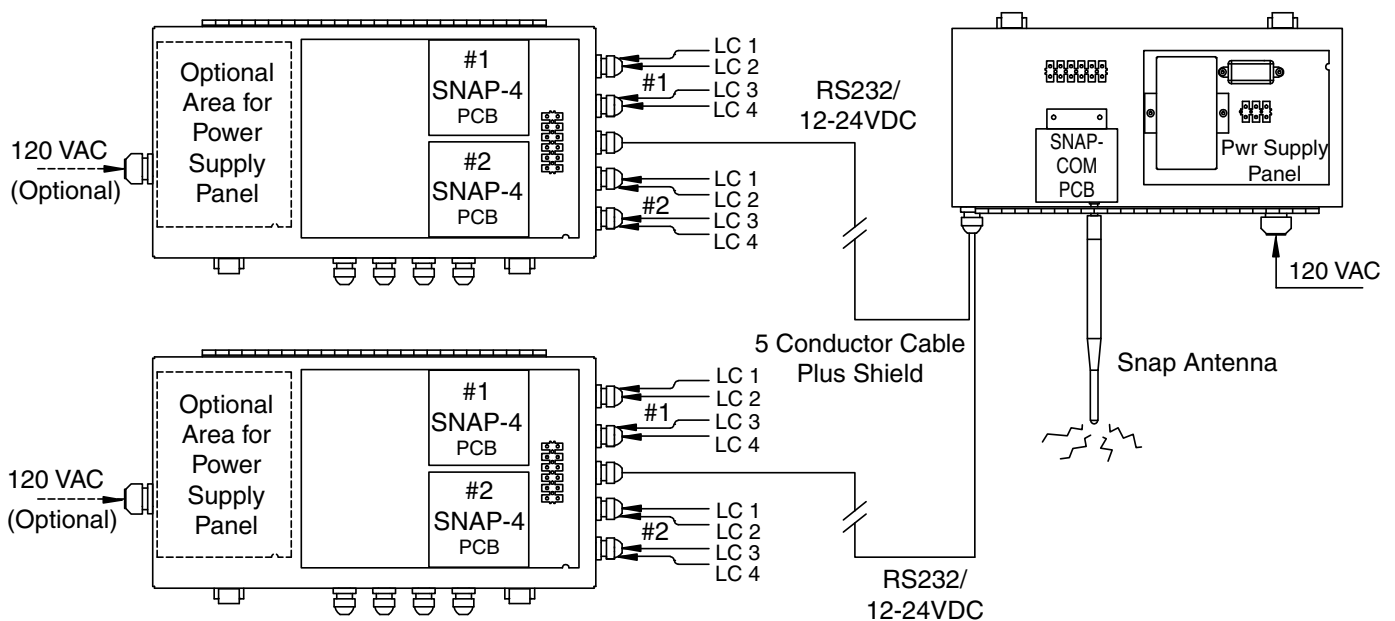

SNAP-4X4

- 1 "Snap Scalebox 4"
- Up to 16 load cells input
- 1 "Snap RF-box"
- SNAP-COM & radio antenna for wireless output
- Power supply panel for 120VAC to DC converter
- Optional to install panel in scalebox enclosure
- 12-24VDC + RS232 communications cable between 2 boxes

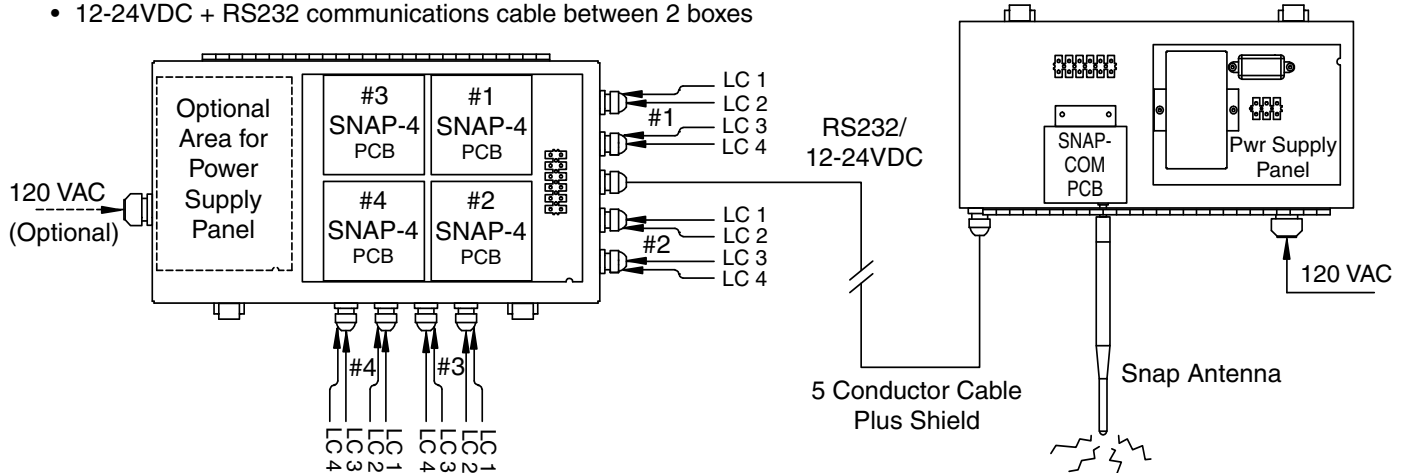

2XX-SNAP

- 1 SnapStream antenna, cable, bracket, and 2XX option card kit
- Installs into any 2XX series indicator or SB500/SB250 series scoreboard
- For radio input/output communications w/other Snap devices

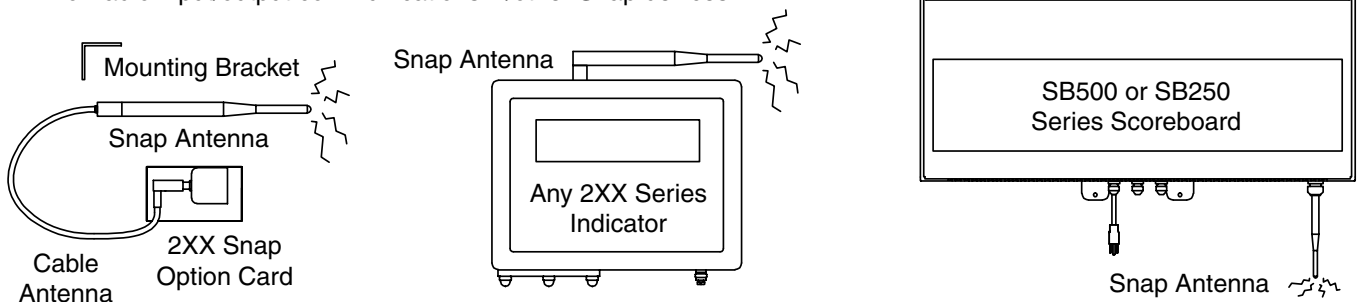

SNAP-COM

- 1 small housing with SnapStream antenna & SNAP-COM board
- 12-24VDC PWR, and USB & 9-pin/RS232 device interface options
- For radio input communications from other Snap devices

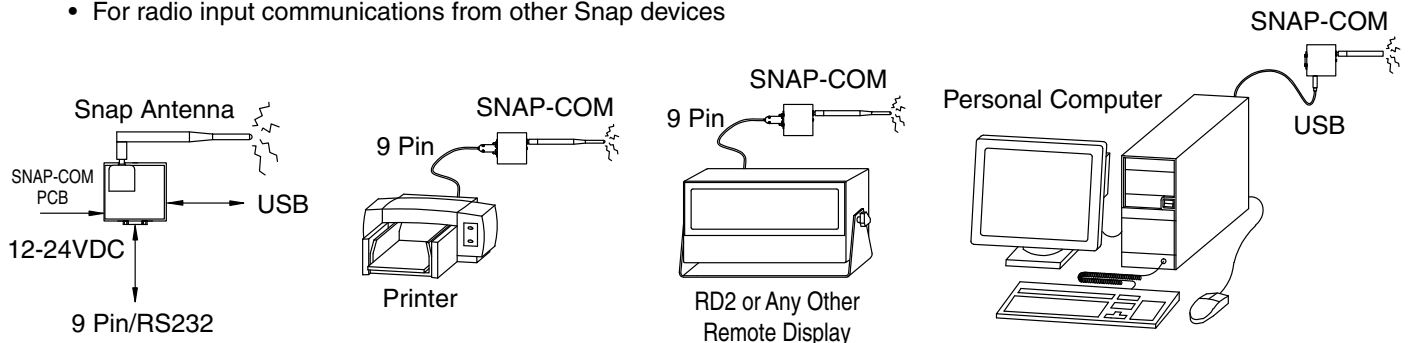

SNAP-COMIP

- 1 small housing with SnapStream antenna & SNAP-COMIP board
- 12-24VDC PWR, and USB & TCP/IP device interface options
- For radio input communications from other Snap devices

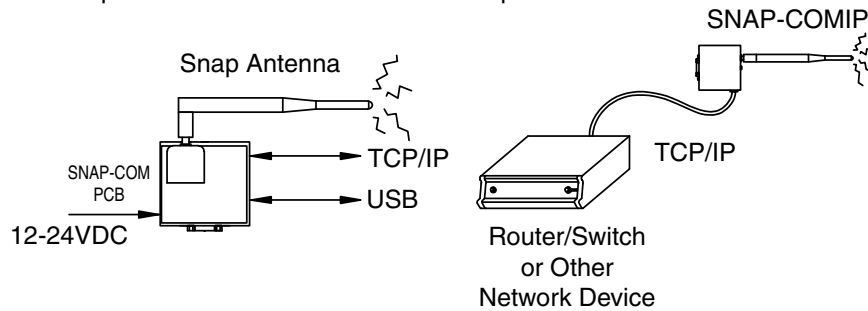

Cardinal Scale reserves the right to improve, enhance or modify features and specifications without prior notice.

SnapStream



The SnapStream Wireless Scale System meets all requirements of Handbook 44, issued by the National Institute of Standards and Technology and has been issued the Certificate of Conformance number **10-085**.



Cardinal[®]
 Cardinal Scale Manufacturing Co.
 203 E. Daugberty, Webb City, MO 64870 USA
 Ph: 417-673-4631 or 800-441-4237 • Fax: 417-673-5001
www.CardinalScale.com

Sold By: